

USTER® *TENSORAPID 4*

TECHNICAL DATA

THE STRENGTH MEASUREMENT SYSTEM



THE STRENGTH MEASUREMENT SYSTEM

Digital tensile testing and analyzing equipment for the quality assurance of a wide variety of yarns and fabrics.

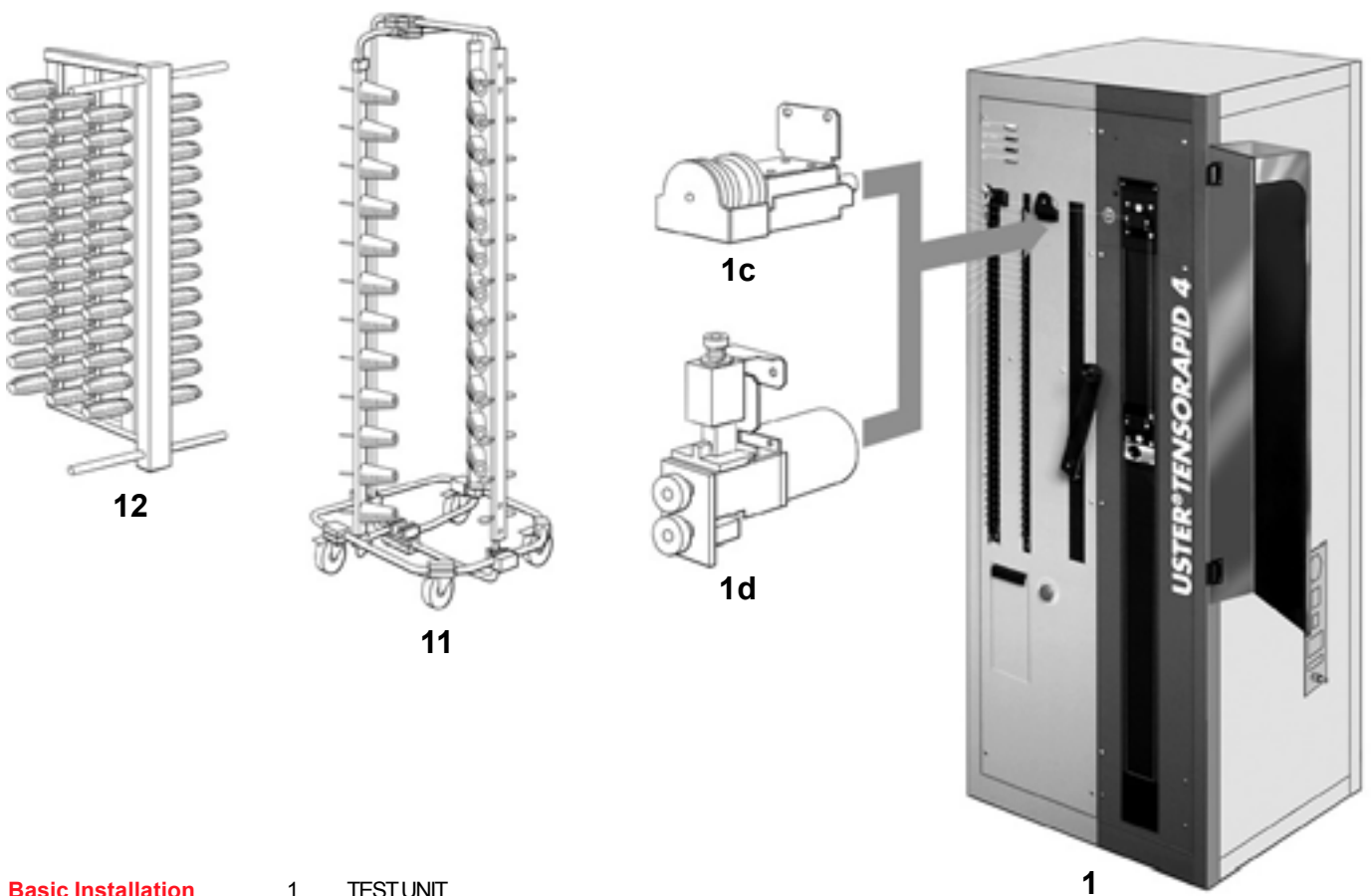

Basic Installation

- 1 TEST UNIT
- 1a Clamping device 500 N
- 1b Clamping device 1500 N
- 1c Plate tensioner
- 1d Rolling-off arrangement
- 2 Operating unit
- 3 Printer
- 4 Calibrating apparatus
- 5 Accessories

THE STRENGTH MEASUREMENT SYSTEM

Options

- 6 ISOINSPECT
Software package FILAMENT (no illustr.)
Network extension UTR4 (no illustr.)

Special Accessories

- 7 Ceramic/hardened steel clamping inserts for force reduction
- 8 Special clamps 180° force reduction curve
- 9 Clamps for woven fabric strips
- 10 Clamps for skein break test
- 11 Package truck 24/40
- 12 Package creel/tensioner carrier
- 13 Vibration absorber
Apparatus table (no illustr.)

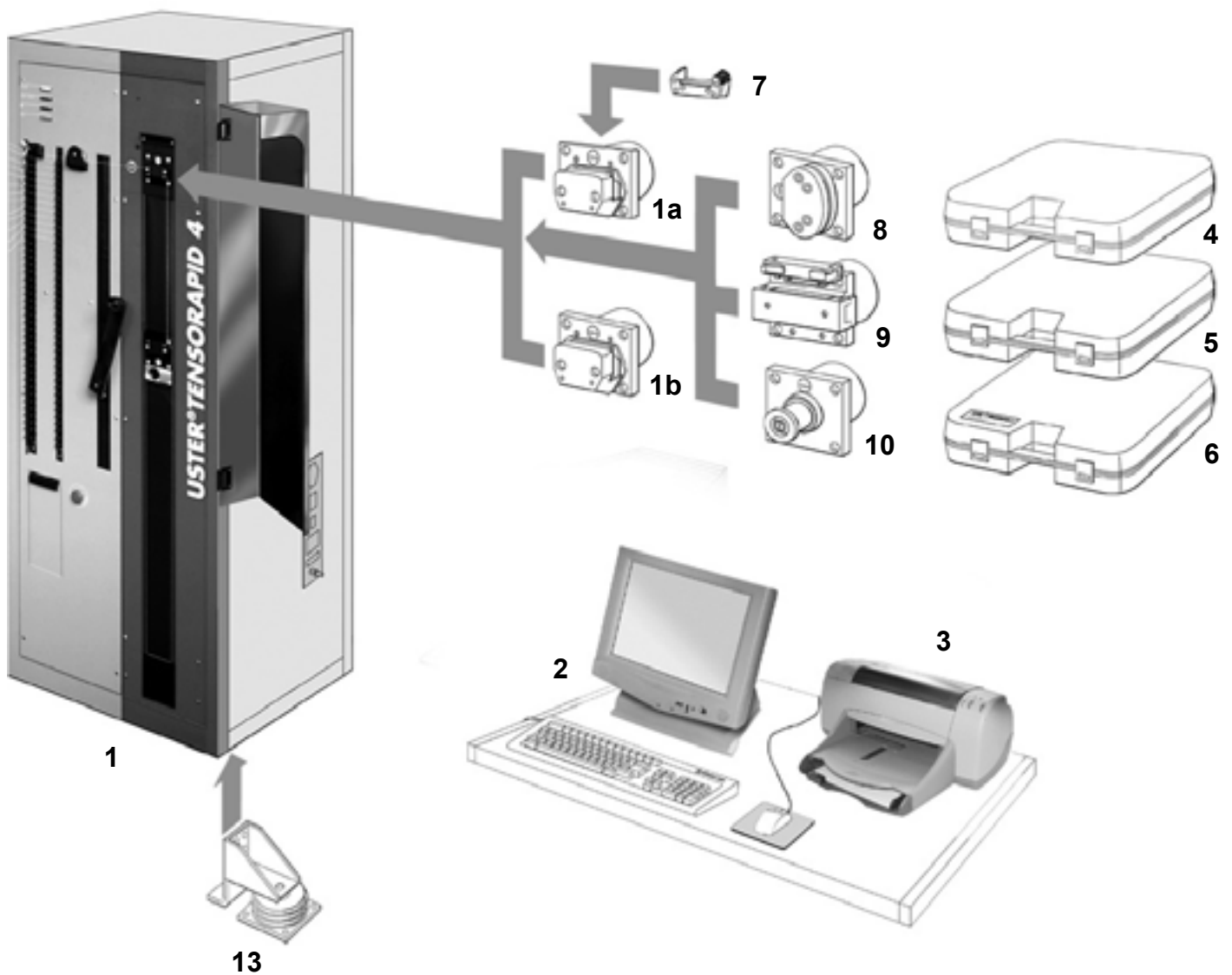

Basic Installation

Overall Installation	<i>Functions:</i>	<ul style="list-style-type: none">• Measurement of tensile strength and elongation of a extensive range of yarns and fabrics.• Collection, evaluation and storage of measurement values and diagrams.• Automatic check of all measured values.• Yarn classification based on the USTER® <i>STATISTICS</i>.• Editor for customizing report layouts.• Filter functions for quick data retrieval and for the preparation of long-term reports.
	<i>Included in the delivery:</i>	<ul style="list-style-type: none">• Operating unit• Screen, keyboard and mouse• System printer• Application software• Backup unit

TEST UNIT (1)	<i>Instrument type 500 N:</i>	<ul style="list-style-type: none">• 0.01 to 500 N (0.001 – 50 kp) *• Recommended for staple fiber yarns, filament yarns (elastomeric yarns on request), ply yarns and fiber assemblies.• Configuration:<ul style="list-style-type: none">– Clamping device 500 N and plate tensioner or– Clamping device 500 N and rolling-off arrangement for the transportation of the yarn between the individual tests. <p>* No exchange of the force transducer required within the specified range</p>
	<i>Instrument type 1500 N:</i>	<ul style="list-style-type: none">• 0.05 – 1500 N (0.005 – 150 kp) *• Recommended for staple fiber yarns and filament yarns coarser than 20 tex, ply yarns, technical yarns, skeins and fabric strips.• Configuration:<ul style="list-style-type: none">– Clamping device 1500 N and plate tensioner or– Clamping device 1500 N and rolling-off arrangement for the transportation of the yarn between the individual tests. <p>* No exchange of the force transducer required within the specified range</p>
	<i>Measuring principle:</i>	Constant rate of extension CRE
	<i>Testing method:</i>	Simple tensile test, single yarn testing, special tests for filament yarns (option).
	<i>Force measuring arrangement:</i>	Practically inertialess electronic force measurement.
	<i>Elongation measuring arrangement:</i>	Electronic elongation measurement. Measuring accuracy for force and elongation measurement, ± 1 cN or $\pm 1\%$.

THE STRENGTH MEASUREMENT SYSTEM

<i>Clamp speed:</i>	Continuously adjustable between 50 and 5'000 mm/min.
<i>Pre-tension:</i>	Adjustable between 0.5 and 6'000 cN (approx. 0.5 to 6'000 p)
<i>Test lengths:</i>	<ul style="list-style-type: none">• With horizontal position of clamps: continuously adjustable between 200 and 1'000 mm• With vertical position of clamps: continuously adjustable between 100 and 1'000 mm
<i>Elongation measuring range:</i>	<ul style="list-style-type: none">• For 100 mm test length: 0 to 1'000%• For 200 mm test length: 0 to 500%• For 500 mm test length: 0 to 140%
<i>Yarn changer:</i>	Device for the automatic changing of the yarn taken from up to 40 packages; manual operation for single measurements is possible.
<i>Yarn clamps:</i>	Pneumatically actuated yarn clamps with exchangeable clamp inserts of various materials, and exchangeable reduction curves (see optional accessories); the clamp pressure is programmable in stages.

Operating Unit (2)

- Personal computer with Microsoft Windows 2000 and USTER® *TENSORAPID 4* specific hard- and software installed in the USTER® *TENSORAPID 4*.
- Power supply for the overall USTER® *TENSORAPID 4* installation.
- User interface: 15" Flatscreen, US ASCII keyboard, 3 key-mouse.
- Backup unit: 2 GB storage capacity for the data backup.

System Printer (3)

Minimal configuration: Ink-jet color printer, actual HP DeskJet printer.

Accessories (5)

<i>Tools:</i>	<ul style="list-style-type: none">– For the exchange of the clamps (e.g. from clamps for fabric strips to clamps for skein test to clamps for high resistance yarns with 180° force reduction curve).– For the exchange of the clamp inserts.– For the exchange of the reduction curve.
<i>Clamp inserts:</i>	To enable the appropriate testing of various types of materials, different clamp inserts are included in the delivered parts.
<i>Safety device:</i>	Protect the operator from dangerous violations while testing high resistance yarns and fabrics.
<i>Plate tensioner*:</i>	Guarantees constant and regular tension on the yarn for reproducible results.
<i>Rolling-off arrangement*:</i>	Allows quick sample control of whole bobbins due to unwinding of long yarn pieces between the measurements with winding speeds up to 400 m/min.

* A choice has to be made

Options

Calibrating Apparatus (4)	<i>Application:</i>	Calibrating and checking of the installation (force transducer).
----------------------------------	---------------------	--

ISOINSPECT (6)	<i>Application:</i>	Checking of the accuracy of the force and elongation measurement.
-----------------------	---------------------	---

Optional Software Package FILAMENT (no illustr.)		Various Modulus (Chord, Young, Secant, Tangent) Tensile-elastic behavior Yield point Natural draw ratio
---	--	--

Optional Accessories

Ceramic/Hardened Steel Clamping Inserts for Force Reduction (7)	<i>Application range:</i>	<ul style="list-style-type: none">• High strength filament yarns and ply yarns.• Undrawn, partially drawn or very fine filament yarns.• Test materials with a tendency to stick to polished surfaces.• Filament yarns with abrasive additives for obtaining matt surfaces (e.g. titanium dioxide).
--	---------------------------	---

Special Clamps 180° (8)	<i>Application range:</i>	<ul style="list-style-type: none">• Automatic testing of high strength yarns (e.g. aramides), technical yarns and oiled, high strength ply yarns.• Testing of difficult materials which in spite of extensive trials with different clamp inserts and a force reduction over 90° reduction curve have so far produced incorrect measurements as a result of slippage or clamp breaks.
--------------------------------	---------------------------	--

Included in the delivery:

- Special clamps with a force reduction over 180°
- Pressure doubler

THE STRENGTH MEASUREMENT SYSTEM

Clamps for Woven Fabric Strips (9)

Application range:

- Testing of woven fabric strips according to DIN 53857 (50 mm width).
- Testing of fiber assemblies for the adhesion test.

Clamps for Skein Break Test «hank test» (10)

Application range:

Clamps for the testing of the skeins (hank test) according to ASTM standard D 1578.

Package Truck 24/40 (11)

Application:

Package truck for creeling and transporting of up to 24 yarn packages (with separate extension set for up to 40 yarn packages).

Package dimensions:

- With 24 packages: max. \varnothing 125 mm; length max. 450 mm
- With 40 packages: max. \varnothing 60 mm; length max. 450 mm

Package Creel/Tensioner Carrier (12)

Application:

- Creel with tensioner carriers for creeling up to 40 yarn packages).
- For measurements on packages where the yarn is taken directly from the package trucks without thread tensioners, the tensioner carriers are also available separately.

Package dimensions:

Max. \varnothing 60 mm

Vibration Absorber (13)

Application:

For measurements of material with a breaking force less than 200 cN, or if vibrations of the floor are to be expected.

Application Software

Reports	<i>Type of report:</i>	<ul style="list-style-type: none"> • Test reports of measurement series. • USTER® Quality Report (summary of the key data and the test results on one page; quality certificate). • USTER® QualiProfile™ (graphic representation of the overall yarn quality, with respect to the USTER® STATISTICS or to customer-specific yarn profile). • Long-term reports.
	<i>Possible representations:</i>	<ul style="list-style-type: none"> • Pre-configured standard reports for different applications. • Editor for the definition of customer-specific reports.
	<i>Display and print-out of the reports:</i>	Choice of: <ul style="list-style-type: none"> – automatic – only in exceptional situations – as required
	<i>Limit values:</i>	<ul style="list-style-type: none"> • Determination of fixed limit values or definition of limit values based on the USTER® STATISTICS stored in the system. • Verification of measured values. • Measured values which exceed the set limits values will be marked.

Numerical Output of Results	<i>Time to break:</i>	Time from the start of measurement to the break of the sample.
	<i>Breaking force:</i>	Maximum force value measured during the tensile test.
	<i>Breaking elongation:</i>	Elongation at maximum breaking force value.
	<i>Tenacity:</i>	Breaking force in relation to the yarn count of the sample.
	<i>Breaking work:</i>	Work done to break (enclosed area below the force/elongation characteristic curve up to the point of breaking force).
	<i>Part work done:</i>	Partial work done to break (enclosed area below the force/elongation characteristic curve and two freely-selected elongation values).
	<i>Reference values:</i>	A maximum of any 10 points on the force/elongation characteristic curve (choice of force or elongation).
	<i>Modulus values:</i>	A maximum of 10 Modulus values at any point on the force/elongation characteristic curve.
	<i>Reference Elongation E(F-):</i>	Elongation at a defined decrease in force from the breaking force up to 90%.
	<i>Force F (1st break):</i>	Force value at a defined decrease in force.

THE STRENGTH MEASUREMENT SYSTEM

Statistical Values	<i>Type of report:</i>	Overall results protocol with statistical data of the results columns.
	<i>Statistical values:</i>	<ul style="list-style-type: none">• Mean value• Standard deviation s• Coefficient of variation CV• 95% confidence range Q95• Minimum value• Maximum value• USP (USTER® STATISTICS percentage)
	<i>USTER® STATISTICS:</i>	<ul style="list-style-type: none">• Material-dependent USTER® STATISTICS are stored in the data-base.• Application:<ul style="list-style-type: none">– for the comparison of measured values with the USTER® STATISTICS– setting of limit values based on the USTER® STATISTICS

Graphic Output of Results	<i>Stroke diagram:</i>	<ul style="list-style-type: none">• Available for breaking force and elongation or for other results configurable.• Individual values can be selected with the aid of the cursor directly on the screen.
	<i>Frequency distribution diagram:</i>	Available for force and elongation or for other results configurable.
	<i>Force/elongation diagram:</i>	<ul style="list-style-type: none">• Contains all single measurements of a package or the calculated mean value curve of a package.• Individual values on the force/elongation line can be selected with the aid of the mouse directly on the screen.
	<i>Modulus/elongation diagram:</i>	Modulus curves of all single measurements of a package.
	<i>Spectrogram:</i>	Available for force and elongation.

Data Storage	<i>Data protection:</i>	<ul style="list-style-type: none">• The data are stored on the hard disk.• For long-term storage, the data can be archived on a backup unit and presented again as required at a later date.• All settings, measurement values and diagram are stored.
	<i>Memory capacity:</i>	<ul style="list-style-type: none">– 5'000 measurements per measurement series with saving of F/E diagrams.– 100'000 measurements per measurement series without saving of F/E diagrams.– 1'000 measurements per measurement series by determination of tensile-elastic behavior.

Input of Data, Output of Results, Languages, Units	<i>Dialog and report languages:</i>	English, German, French, Italian or Spanish can be selected via the operating menu (other languages on request).
	<i>Possible units:</i>	<ul style="list-style-type: none">• Force values: DN, N, cN, kgf, gf, lbf, ozf• Yarn count: ktex, tex, dtex, denier, Nm, Nec, Nel, New, grn/yd, Y.S.W.• Tenacity: mN/tex, cN/tex, gf/denier, Rkm, CSP, MPA

THE STRENGTH MEASUREMENT SYSTEM

Selftest	<i>Function check:</i>	<ul style="list-style-type: none">• Initiated automatically when the installation is switched on.• Comprehensive function check and special test programs can be initiated at any time via the diagnosis menu.
	<i>Calibration:</i>	<ul style="list-style-type: none">• The calibration of the installation is carried out with the aid of the calibrating apparatus.• The inspection and calibration can be performed by the operating personnel.
	<i>Checking of the measuring accuracy:</i>	<ul style="list-style-type: none">• The measuring accuracy is checked by means of the ISOINSPECT option.• The measuring accuracy of the installation can be checked by the operating personnel.

General

General Ambient Conditions	<i>Room climate:</i>	The ambient conditions must be maintained in order to avoid any influencing of the test material. <ul style="list-style-type: none">– Relative humidity: (65±2)% relative humidity– Temperature: according to ISO 139-1973 or DIN 53 802 (20±2) °C for temperate climates (27±2) °C for tropical climates
	<i>Max. conditions:</i>	80% relative humidity, non-condensing Temperature >+10 °C and <30 °C

Installation Data	<i>Electrical connection:</i>	Single-phase mains with protective conductor
	<i>Nominal voltages:</i>	200 to 250 VAC; +6/–10% 100 to 145 VAC; +6/–10%
	<i>Mains frequency:</i>	48 – 62 Hz
	<i>Power consumption:</i>	Approx. 1'000 VA
	<i>Compressed air connection:</i>	Air quality: according to ISO 8573.1, class 3 Min. pressure at inlet of air filter regulator: 6 bar Max. pressure at inlet of air filter regulator: 10 bar
	<i>Compressed air consumption:</i>	9 m ³ /h with normal pressure. Noise level at the suctioning-off jet: approx. 65 to 70 dB(A) at 1 m distance and according of the type of yarn.

