



USTER® AFIS PRO 2

The fiber process control system

Technical Data

December 2021

USTER® AFIS PRO 2

The fiber process control system

The Uster Afis Pro 2 instrument measures the most important fiber properties for process control purposes in a spinning mill. These are neps, length, maturity, and trash in cotton fibers and blends as described under 'Applications' below. These are essential measurements for the spinning mill to optimize its spinning operation based on the raw material purchased.

Elements of the Uster Afis Pro 2 installation

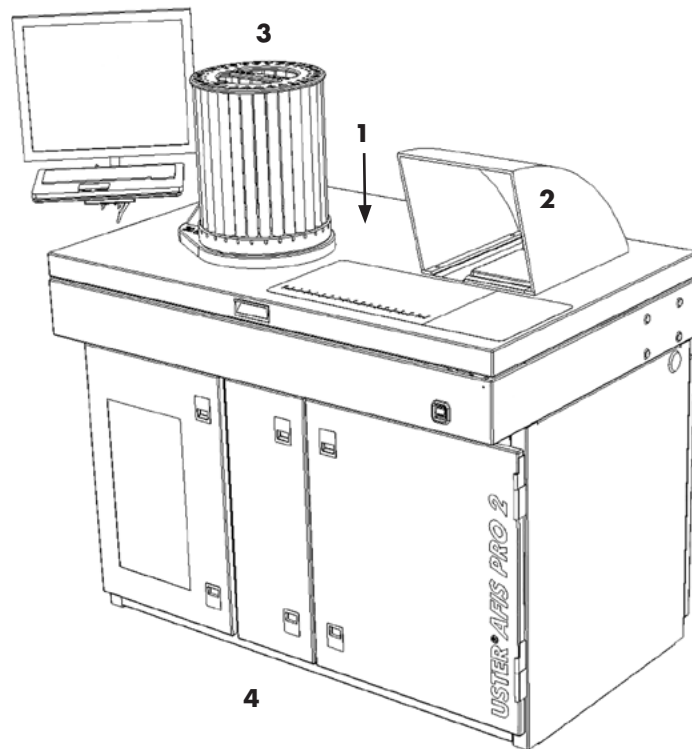

Basic installation

- 1 Neps/Length/Maturity Module (inside)
- 2 Balance
- 3 Autojet Module (Optional Module)
- 4 Operating Unit

Optional Modules

- Trash Module
- Autojet Module

USTER® AFIS PRO 2

The fiber process control system

Basic installation

Overall installation

Functions

- Measurement of raw cotton bale fiber, mat, sliver and roving for properties of neps, length, maturity and trash
- Collection, evaluation and storage of measurement data
- Editor for configuring, viewing, and printing module and bale data
- Filter functions for quick data retrieval and for the preparation of long-term reports

Versions

- Uster Afis Pro 2 with neps, length, maturity
- Uster Afis Pro 2 with neps, length, maturity, Autojet
- Uster Afis Pro 2 with neps, length, maturity, trash
- Uster Afis Pro 2 with neps, length, maturity, trash, Autojet

Included in the delivery

- Operating unit consisting of:
 - Neps, Length, Maturity Module
 - Balance
- Application software
- Calibration materials
- Trash Module (Optional)
- Uster Autojet (Optional)
- Spare Parts Kit (Optional)

Neps, Length, Maturity Module (1)

Functions

- Measurement total nep count, total nep meansize, fiber nep count, fiber nep mean size, seedcoat nep count, seed coat nep mean size by way of Electro-optic Sensor
- Measurement of length values by weight (w): Mean length, mean length CV%, short fiber content, upper quartile length by way of electro-optic sensor
- Measurement of length values by number (n): Mean length, mean length CV%, short fiber content, 5% length by way of electro-optic sensor
- Measurement of fineness, maturity ratio, immature fiber content by way of electro-optic sensor

Balance (2)

Functions

- Used for weighing the sample

USTER® AFIS PRO 2

The fiber process control system

Operating unit (4)	Main equipment	Base Unit containing the Nep, Length, Maturity Module without the Autojet Module.
	Computer software	The Uster Afis Pro 2 software has a menu driven design that allows quick access and selection of testing, setup, calibration, and data management. These features include: <ul style="list-style-type: none">– Windows 10 operating system with icon-based software– Simple user interface– Error messages for troubleshooting– Network capabilities
	Computer hardware	Industrial computer system consisting of the following components: <ul style="list-style-type: none">– Keyboard with integrated touchpad and mouse– Monitor– Balance

Optional Modules

Trash (T) Module	Functions	<ul style="list-style-type: none">– Measurement of total trash count, total trash size, dust count, dust mean size, trash count, trash mean size, visible foreign matter by way of Electro-optic Sensor
Autojet	Functions	<ul style="list-style-type: none">– Automatic feeding device for measuring up to 30 samples automatically, reducing idle operating time

Calibration materials

Standard calibration materials	<ul style="list-style-type: none">– One set of calibration materials is included with each instrument shipment– Calibration materials are provided by Uster for Uster Afis Pro 2 for calibration of the following parameters:<ul style="list-style-type: none">– length– maturity– neps
--------------------------------	--

USTER® AFIS PRO 2

The fiber process control system

Additional features

- Safety interlocks to prevent injury from un-authorized entry to the instrument
- Relative humidity and temperature probe
- Easily accessible lint waste box with front access doors
- Computer system easily removed for service
- Industrial brushed stainless steel top and work surfaces
- Integrated air enclosure around balance to eliminate influences of air turbulence
- Password protected operational software
- Complete operator manual included

Application software

Reports

Type of reports

- Application reports
 - Roller spacing
 - Critical nep size
- Control charts
 - Control chart individual
 - Control chart multiple
- Data reports
 - Individual rep histogram
 - Summary histogram
 - Summary tables

Display and print-out of the reports

- Automatic reports
- Configurable reports

Limit values

- Limits can be set for a specified measured parameter in the control charts

USTER® AFIS PRO 2

The fiber process control system

Numerical
output of results

Neps

Total nep cnt	Count of all neps in a sample (fiber and seed coat neps)
Total nep mean size	Average size of all neps (fiber and seed coat neps) counted in microns
Fiber nep cnt	Count of all fiber neps
Fib nep mean size	Average size of all fiber neps in microns
SC nep count	Count of all seed coat neps
SC nep mean size	Average size of all seed coat neps in microns

Length

L (w)	Average fiber length by weight of all the cotton fibers in the sample
L (w) CV%	Variation of the fiber length around the average is expressed as length variation by weight or CV%
SFC (w) %	Percent of all fibers in a cotton sample that are shorter than 12.7 mm (0.5 in.) by weight
UQL (w) %	Length by which 25% of all fibers by weight exceed in a cotton sample
L (n)	Average fiber length by number of all cotton fibers in the sample
	Variation of the fiber length around the average is expressed as length variation by number or CV%
SFC (n)%	Percent of all fibers in a cotton sample that are shorter than 12.7 mm (0.5 in.) by number
5% L (n)	Length of the longer 5% of all fibers in a cotton sample

Maturity

Fineness	Calculation of the fineness of the fiber based on shape and form of the fibers
Maturity ratio	Calculation of the maturity based on shape and form and related to the cell wall thickness or Theta
IFC%	Percentage of all fibers in a cotton sample that have a cell wall thickness covering less than 25% of the full area

USTER® AFIS PRO 2

The fiber process control system

Numerical output of results (Trash Module)	Total trash count	Count of all particles (dust and trash particles)
	Total trash size	Average size of all particles counted (dust and trash particles)
	Dust count	Count of all particles less than 500 microns in size
	Dust mean size	Average size of all dust particles counted
	Trash count	Count of all particles greater than 500 microns in size
	Trash mean size	Average size of all trash particles counted
	VFM%	Calculation taking both dust and trash content as well as size into account; relates to gravimetric trash measurement methods such as Shirley Analyzer
Statistics	Statistical values	Overall measurement protocol with statistical data in the result columns <ul style="list-style-type: none"> - Mean (Average) - Standard deviation - Coefficient of variation CV% - 99% confidence range - Min. value - Max. value
Data protection	Backup	<ul style="list-style-type: none"> - A 2nd hard disk (with identical storage capacity) is available for data and image backup purposes. - Backup software is provided for the user to create a backup image of the primary hard disk.
Input of data, output of results, languages, units	Dialog and report languages	English, Chinese, Spanish, Turkish and Portuguese can be selected via the operating menu (other languages on request).
	Possible units	<ul style="list-style-type: none"> - Length: mm, in - Short Fiber: 0.5 in, 12.7 mm, 16 mm
	Test time	2.5 to 3.5 minutes per repetition, variable depending on operator experience and material type.
Selftest	Function check	Comprehensive function check and special test programs can be initiated at any time via the diagnosis menu.

Application range

Naturally (white, cream) colored 100% cotton samples in the form of bale or opened and cleaned material (card mat), sliver, and roving. Waste material cannot be tested on the Uster Afis Pro 2. Doing so can damage instrument components, and voids the instrument and component warranty.

Naturally colored, synthetic fibers can only be tested up to a 50/50% blend with cotton fibers in sliver and roving form. Uster Technologies does not guarantee test results on 100% synthetic fibers. Maximum fiber length: 2 inches (app. 50 mm).

Measurements

- Neps (fiber neps and seed coat neps)
- Length (mean, UQL, 5%, and short fiber)
- Maturity (fineness, maturity ratio, immature fiber content)
- Trash (Optional) (trash, dust, and visible foreign matter)

Measurements

All measurements are performed optically on individual fibers and particles (neps and trash).

Nep classification	Fiber and seed coat nep count per gram and size (μ) distribution.
Length	Fiber length by number and by weight distributions; short fiber content by number and by weight (%).
Maturity	Maturity, immature fiber content (%) and fineness (mtex) distribution.
Trash	Dust and trash count per gram and size (μ) distribution; visible foreign matter content (%).

USTER® AFIS PRO 2

The fiber process control system

General

General ambient conditions

Room climate

According to ISO 139, the following ambient conditions must be maintained in the laboratory in order to get repeatable and comparable test results:

- Temperature: 20 ± 2 °C; 65 °F to 72 °F
- Relative humidity: 65 ± 2 %

For consistent test results, fiber samples should be conditioned in the laboratory environment with the above-mentioned ambient conditions for 24 hours. Samples should be laid out openly in the laboratory, and taken out of plastic bags, in order for the cotton to fully condition to the environment.

Uster Technologies recommends use of a dedicated conditioning system for the laboratory to achieve this condition. Uster does not recommend the use of any spray atomizers as they could result in damage to the instruments, variability in lab conditioning, and may cause inconsistent test results. All Uster certified laboratories use dedicated conditioning systems.

Installation data

Power

The following power requirements apply to both North American and European-type systems.

Voltage (nominal):	208 or 230 volts ± 10 % (single phase)
Current:	<10 Ampere (dedicated circuit breaker)
Frequency:	50 – 60 Hertz
Harmonic distortion:	<5%
Wire size:	Sufficient to have <5% drop from no load to full load
Electrical interference:	Free of transient voltages from other equipment

The Uster Afis Pro 2 requires a separate, dedicated 10-Ampere circuit breaker at the facility's electrical load center. During normal operation the instrument draws approximately 5 Ampere. A power cord for connection is provided with the Uster Afis Pro 2. The opposite end must be fitted with connections compatible with the facility's electrical system.

USTER® AFIS PRO 2

The fiber process control system

Compressed air

The air supplied to the instrument should comply with ISO 8573.1 quality class 3 as follows:

- Dirt particle size: <5 microns
- Water pressure dew point: <4 °F @ 100 PSIG (128 ppm by volume)
- Oil (including vapor): <1.0 ppm
- Air pressure: 100 – 150 PSIG (700 – 1,034 kPa)
- Air volume: The instrument requires at least three SCFM (85 liters/min) supplied by a 10 mm (3/8 inch) line.
- Laboratory temperature: These specifications are for the ambient conditions referenced above. If the airline will be subjected to temperatures that could promote condensation, a water filter attached to the airline inside the lab is recommended to remove any condensation that may occur.

Space required for the installation of the Uster Afis Pro 2

The Uster Afis Pro 2 is a single cabinet installation. The following is a breakdown of the instrument dimensions and weight.

Dimensions

Length	Width	Height from floor
118 cm (46.5 in.)	76 cm (30 in.)	97.4 cm (38.3 in.)

Gross weight of the basic installation

Total	185 kg (408 lbs)
--------------	------------------

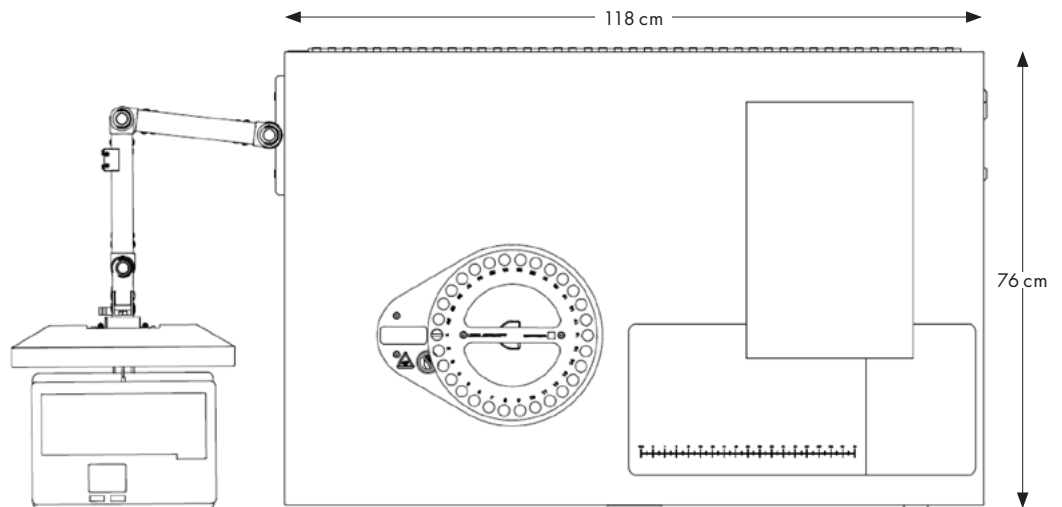

Uninterrupted power supply (UPS) specifications and recommendations

Uster Technologies requires that an Uninterruptible Power Supply (UPS) be used to prevent loss of data or other related problems. It is a requirement for the installation and commissioning of the unit and the responsibility of the customer to provide it at the time of installation. The following specifications should be noted:

FULL System UPS

Highly recommended and even required in many countries where quality of AC power issues is common. Specifications:

Input

Voltage 208 – 240 VAC

Frequency 50/60 Hz

Output

Topology Double Conversion

Mode of operation Online

Power Capacity 3.0 KVA

Waveform Type Sine wave

Nominal Output Voltage 208 – 240 VAC

Voltage regulation +/-2%

Frequency Synchronized to input

Surge Protection/Filtering

AC Surge Protection Greater than 300 joules

Filtering Preferred

Examples of approved UPS manufacturer models:

MFG	Part	Rating	Capacity (min)
APC	SRT3000XLT+SRT96BP(1X)	3.5 KVA	15
APC	SRT3000XLT+SRT96BP(2X)	3.5 KVA	30
APC	SRT3000XLT+SRT96BP(3X)	3.5 KVA	60
CyberPower	OL3000RTL2UHVN	3.5 KVA	5
TrippLite	SU3000LCD2UHV	3.5 KVA	5

USTER® AFIS PRO 2

The fiber process control system

Partial System UPS (Not recommended – mainly for PC data protection only)

Specifications:

Input

Voltage 208 – 240 VAC

Frequency 50/60 Hz

Output

Topology Double Conversion

Mode of operation Online

Power Capacity 1.5 KVA

Waveform Type Sine wave

Nominal Output Voltage 208 – 240 VAC

Voltage regulation +/-2%

Frequency Synchronized to input

Surge Protection/Filtering

AC Surge Protection Greater than 300 joules

Examples of approved UPS manufacturer models:

MFG	Part	Rating	Output Capacity
Xtreme Power	P90g-1500	1,500 VA	TBD
TrippLite	SUINT1000LCD2U	1,000 VA	6 min @ 750 W
TrippLite	SUINT1500LCD2U	1,500 VA	6 min @ 1,100 W

Uster Technologies has made all possible efforts to ensure that all information is accurate at the time of publication. Hereby it is declared that alterations to the product may be possible at any time. In these cases the information contained in this technical datasheet is subject to change without notice.

December 2021



Uster Technologies AG

Sonnenbergstrasse 10

8610 Uster

Switzerland

T. +41 43 366 36 36

F. +41 43 366 36 37

sales@uster.com

www.uster.com